

# TIMKEN

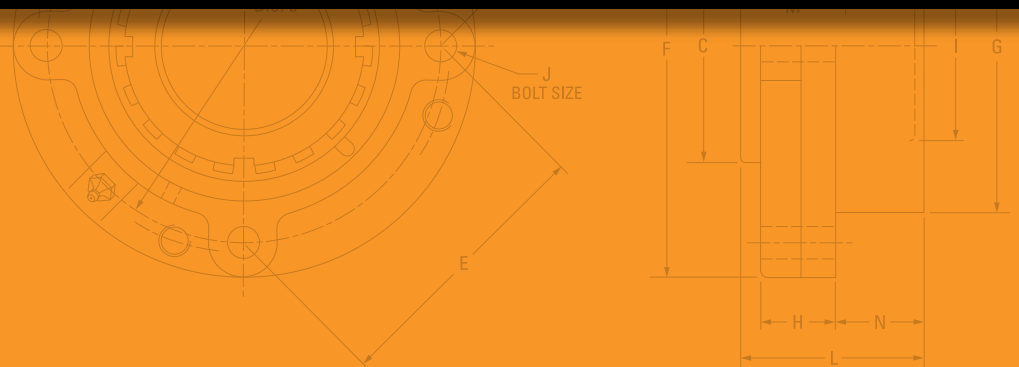

## TIMKEN® TAPERED ROLLER BEARING TYPE E HOUSED UNITS





# **TIMKEN® HOUSED UNIT CATALOG INDEX**

OVERVIEW.....	2
INTRODUCTION.....	4
SHELF LIFE POLICY.....	10
Tapered Roller Bearing Type E Housed Units.....	B-1



## ***GROW STRONGER WITH TIMKEN***

Every day, people around the world count on the strength of Timken. Our expertise in metallurgy, friction management and mechanical power transmission helps them accelerate improvements in productivity and uptime.

We supply products and services that can help keep your operations moving forward, whether you need drive train kits for commercial vehicles, durable housings for bearings in dirty environments, couplings that avoid metal-to-metal contact between motors and gearboxes, repair services for rail bearings, steel for an aircraft engine shaft, or other products and services for your applications.

When you choose Timken, you receive more than high-quality products and services: You gain a worldwide team of highly trained and experienced Timken people committed to working collaboratively with you to improve your business.

Globally, our 20,000 people provide reliable answers for a wide range of operations in manufacturing, mining, medical equipment, aerospace, transportation, oil and gas – and other diverse industries.

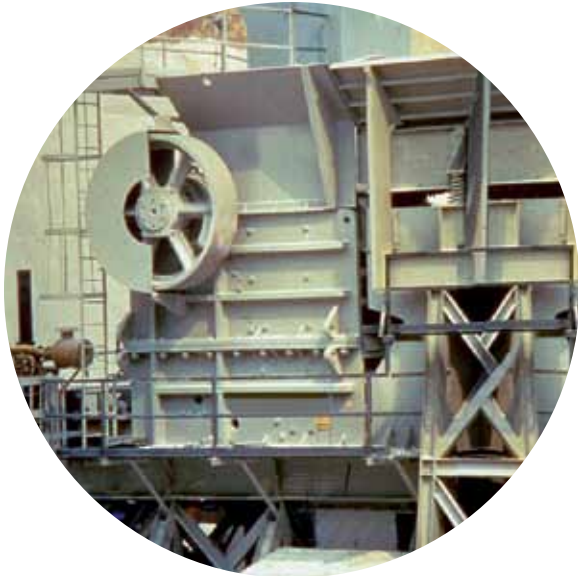

## ***INCREASE YOUR EQUIPMENT UPTIME***

In addition to high-quality bearings, engineered steel and mechanical power transmission components, we provide valuable integrated products and services. For example, we offer repair services and equipment monitoring equipment that can alert you to problems before they impact your uptime.

Additionally, we offer a broad selection of seals, premium lubricants, lubricators, couplings and chain to keep your operations moving smoothly.

Our 10 technology centers in the United States, Europe and Asia help pioneer tomorrow's innovations with extensive basic and applied scientific research programs. Through internal development and strategic acquisition of innovative companies, we continue to expand our portfolio of highly engineered bearings, steel and components.



## ***RUGGED TIMKEN® HOUSED UNITS HELP PROTECT YOUR BEARINGS***

When you choose sturdy Timken housings, your bearings can keep rolling smoothly, even in harsh environments impacted by dirt, debris, water and other contaminants. Timken engineers designed special housings to withstand tough challenges on the job.

Protected inside durable cast iron or steel, our highly engineered Timken® ball and roller bearings work hard to help you manufacture and transport materials, without excessive maintenance due to contaminants.

Choose from our selection of housed units designed with ball, tapered and spherical bearings. Select enhancements like Timken® seals, lubricants and housing covers best suited for each task. Our engineers help you choose the right combination of bearings and accessories to extend bearing life, increase uptime and reduce maintenance costs.

Of course, you can interchange existing products with Timken housed units because our bolt holes and shaft centerline dimensions are designed to conform to industry standards.

Timken® housed units reflect our strengths in metallurgy, engineering and manufacturing. We produce all our bearings in adherence with the Timken Quality Management System for consistency in all our facilities around the world.



## TIMKEN® BALL HOUSED UNITS OFFER EASY INSTALLATION, FLEXIBLE OPTIONS

Timken® ball housed units, available in a variety of sizes and types, feature wide-inner-ring ball bearings that provide additional shaft support and locking options. The Timken® wide-inner-ring ball bearing is designed for straight shafts and can be positioned without shoulders, locknuts or adapters.

For easy installation, our ball housed units can be ordered pre-assembled with bearings, housings, seals and locking systems. Choose from pillow blocks, flanged cartridges, take-up units and cylindrical cartridges. Our cast-iron, pressed-steel and other optional materials give you durable choices for the exterior covers. Timken® locking options include set screws, self-locking collars and concentric collars.

Timken® Shaft Guarding Technology™ deters set-screw damage to shafts by placing a hardened band in the groove along the inner ring of the bearing. The set screws press against the band to transfer gripping pressure onto the shaft, preventing nicks, as well as raised-metal or permanent shaft damage. The stainless-steel band resists corrosion on the shaft. This system is particularly helpful for applications where it would be expensive and time-consuming to replace shafts.

## TYPICAL INDUSTRIES AND APPLICATIONS

Use Timken ball bearing housed units in agricultural applications, fans, blowers, food processing devices and conveyors.



## TIMKEN® TYPE E HOUSED UNITS REPEL CONTAMINANTS, ENHANCE PERFORMANCE

Timken® Type E tapered roller bearing housed units feature double-lip seals and locking collars that protect against water and other contaminants. This double-lip seal design blocks debris and retains grease better than single-lip or triple-lip seals, according to Timken 2012 laboratory tests.

Its cast-iron exterior includes a corrosion-resistant electro-coat finish for the housing and collar, a more durable shield than industry-standard powder coating or black oxide. Set screws with nylon patches reduce back-out, even in rigorous applications.

Premium Timken® tapered roller bearings inside Type E housings are manufactured with advanced technology that results in longer predicted useful bearing life than other housed units with standard bearings. Designed with optimized bearing profiles and improved surface finishes, Timken tapered roller bearings operate efficiently within the housing.

### TYPICAL INDUSTRIES AND APPLICATIONS

Use Timken Type E housings for pulp and paper, power generation, mining, cement and aggregate industries. Our Type E housed units also are widely used in equipment for air-handling and treatment of water and waste water. Other common machine applications include mixers, washers, shredders, mills and oven/furnace roller beds.



## TIMKEN® SPHERICAL ROLLER BEARING SOLID-BLOCK HOUSED UNITS WITHSTAND HARSH CONDITIONS

Timken® spherical roller bearing solid-block housed units stand up to rugged conditions. Composed of solid steel, they withstand most falling debris and handle up to  $\pm 1.5$  degrees of misalignment. The steel used in these products is up to two times stronger than cast iron, which may break or pound out in tough applications.

Timken spherical roller bearing solid-block housed units come in five locking configurations: single and double set screws, eccentric locks for reversing applications, tapered-adaptor locks and double-tapered locks.

Choose from three sealing options: labyrinth seals (for high-speed, high-temperature applications) and triple-lip seals made of either nitrile or urethane. Timken® steel auxiliary covers provide an extra layer of protection, and they can be filled with Timken lubricants.

### TYPICAL INDUSTRIES AND APPLICATIONS

Use Timken spherical roller bearing solid-block housed units in metals mills, aggregate and cement, mining, power generation, agriculture, pulp, paper, sawmills and other forest industries.



### TIMKEN® SAF SPLIT-BLOCK HOUSED UNITS BEAR HEAVY LOADS

Timken® SAF split-block housed units are available in rugged cast iron, ductile iron or cast steel to match a range of industrial environments. Our Timken SAF housed units have separate, matched caps and bases. In larger sizes where housed units are heavier, this split-block design eases installation. Remove the cap using a pry-tool slot for bearing inspection, service and replacement.

Available in a variety of shaft sizes, Timken SAF units offer the choice of tapered-bore design for easy mounting or a straight-bore design for better axial location. The block can be converted from fixed to float by removing the stabilizing ring. Several sealing options protect against contamination, including a standard seal, which is a precision aluminum triple-ring labyrinth seal.

### TYPICAL INDUSTRIES AND APPLICATIONS

Use Timken SAF housed bearings in power generation, coal, mining, aggregate, cement, metals, pulp, paper and other forestry operations, water treatment and food processing industries. Applications include warehousing, conveyors, movable bridges/heavy structures, industrial fans and blowers.



## HOW TO USE THIS CATALOG

We designed this catalog to help you find the Timken housed units best suited to your specifications.

Timken offers an extensive range of bearings and accessories in both imperial and metric sizes. For your convenience, size ranges are indicated in millimeters and inches. Contact your Timken engineer to learn more about our complete line for the special needs of your application.

This publication contains dimensions, tolerances and load ratings, as well as engineering sections describing fitting practices for shafts and housings, internal clearances, materials and other bearing features. It provides valuable assistance in the initial consideration of the type and characteristics of the bearings that may best suit your particular needs.

ISO and ANSI/ABMA, as used in this publication, refer to the International Organization for Standardization and the American National Standards Institute/American Bearing Manufacturers Association.

**Updates are made periodically to this catalog. Visit [www.timken.com](http://www.timken.com) for the most recent version of the Timken® Housed Unit Catalog.**

### DISCLAIMER

*This catalog is provided solely to give you analysis tools and data to assist you in your product selection. Product performance is affected by many factors beyond the control of Timken. Therefore, you must validate the suitability and feasibility of all product selections for your applications.*

*Timken products are sold subject to Timken terms and conditions of sale, which include our limited warranty and remedy. You can find these at <http://www.timken.com/en-us/purchase/Pages/TermsandConditionsofSale.aspx>.*

*Please consult with your Timken engineer for more information and assistance.*

*Every reasonable effort has been made to ensure the accuracy of the information in this writing, but no liability is accepted for errors, omissions or for any other reason.*



## ***SHELF LIFE AND STORAGE OF GREASE-LUBRICATED BEARINGS AND COMPONENTS***

To help you get the most value from our products, Timken provides guidelines for the shelf life of grease-lubricated ball and roller bearings, components and assemblies. Shelf life information is based on Timken and industry test data and experience.



### **SHELF LIFE POLICY**

Shelf life should be distinguished from lubricated bearing/component design life as follows:

- Shelf life of the grease-lubricated bearing/component represents the period of time prior to use or installation.
- The shelf life is a portion of the anticipated aggregate design life. It is impossible to accurately predict design life due to variations in lubricant bleed rates, oil migration, operating conditions, installation conditions, temperature, humidity and extended storage.
- Shelf life values, available from Timken, represent a maximum limit and assume adherence to the storage and handling guidelines suggested in this catalog or by a Timken associate. Deviations from the Timken storage and handling guidelines may reduce shelf life. Any specification or operating practice that defines a shorter shelf life should be used.

Timken cannot anticipate the performance of the grease lubricant after the bearing or component is installed or placed in service.

### **TIMKEN IS NOT RESPONSIBLE FOR THE SHELF LIFE OF ANY BEARING/COMPONENT LUBRICATED BY ANOTHER PARTY.**

### **European REACH Compliance**

Timken lubricants, greases and similar products sold in standalone containers or delivery systems are subject to the European REACH (**R**egistration, **E**valuation, **A**uthorization and **R**estriction of **C**hemicals) directive. For import into the European Union, Timken can sell and provide only those lubricants and greases that are registered with ECHA (**E**uropean **C**hemical **A**gency). For further information, please contact your Timken engineer.

## STORAGE

Timken suggests the following storage guidelines for our finished products (bearings, components and assemblies, referred to as “products”):

- Unless directed otherwise by Timken, products should be kept in their original packaging until they are ready to be placed into service.
- Do not remove or alter any labels or stencil markings on the packaging.
- Products should be stored in such a way that the packaging is not pierced, crushed or otherwise damaged.
- After a product is removed from its packaging, it should be placed into service as soon as possible.
- When removing a product that is not individually packaged from a bulk pack container, the container should be resealed immediately after the product is removed.
- Do not use product that has exceeded its shelf life as defined in the Timken shelf life guidelines statement.
- The storage area temperature should be maintained between 0° C (32° F) and 40° C (104° F); temperature fluctuations should be minimized.
- The relative humidity should be maintained below 60 percent and the surfaces should be dry.
- The storage area should be kept free from airborne contaminants such as, but not limited to, dust, dirt, harmful vapors, etc.
- The storage area should be isolated from undue vibration.
- Extreme conditions of any kind should be avoided.

Due to the fact that Timken is not familiar with your particular storage conditions, we strongly suggest following these guidelines. However, you may be required by circumstances or applicable government requirements to adhere to stricter storage requirements.





Most bearing components typically ship protected with a corrosion-preventive compound that is not a lubricant. These components may be used in oil-lubricated applications without removal of the corrosion-preventive compound. When using some specialized grease lubrications, we advise you to remove the corrosion-preventive compound before packing the bearing components with suitable grease.

We pre-pack most housed unit types in this catalog with general-purpose grease suitable for their normal applications. It may be necessary for you to frequently replenish the grease for optimum performance.

Be careful in selecting lubrication, however, since different lubricants are often incompatible. You may order housed units pre-lubricated with a specified lubrication.

When you receive a bearing or housed unit shipment, do not remove products from their packaging until they are ready for mounting so they do not become corroded or contaminated.

Store bearings and housed units in an appropriate atmosphere so they remain protected for the intended period.

**WARNING**

***Failure to observe the following warnings could create a risk of death or serious injury.***

Proper maintenance and handling practices are critical. Failure to follow selection recommendations and installation instructions and to maintain proper lubrication can result in equipment failure.

Overheated bearings can ignite explosive atmospheres. Special care must be taken to properly select, install, maintain, and lubricate housed unit bearings that are used in or near atmospheres that may contain explosive levels of combustible gases or accumulations of dust such as from grain, coal, or other combustible materials. Consult your equipment designer or supplier for installation and maintenance instructions.

**CAUTION**

***Failure to follow these cautions could create a risk of injury.***

Do not use damaged housed units. The use of a damaged housed unit can result in equipment damage and/or injury.

**CAUTION**

***Failure to follow these cautions may result in property damage.***

If hammer and bar are used for installation or removal of a part, use a mild steel bar (e.g., 1010 or 1020 grade). Mild steel bars are less likely to cause release of high-speed fragments from the hammer, bar or the part being removed.

**NOTE**

*Do not use excessive force when mounting or dismantling the unit.*

*Follow all tolerance, fit, and torque recommendations.*

*Always follow the Original Equipment Manufacturer's installation and maintenance guidelines.*

*Ensure proper alignment.*

*Never weld housed units.*

*Do not heat components with an open flame.*

*Do not operate at bearing temperatures above 121° C (250° F).*

**Warnings for this product line are in this catalog and posted on [www.timken.com/en-us/products/warnings/Pages/TimkenHousedUnitWarnings.aspx](http://www.timken.com/en-us/products/warnings/Pages/TimkenHousedUnitWarnings.aspx).**



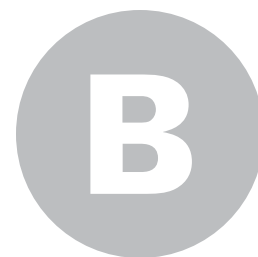

## TAPERED ROLLER BEARING TYPE E HOUSED UNITS

Timken® Type E housed units strengthen the performance of your equipment with industry-leading premium tapered roller bearings encased in protective blocks.

Compared to standard bearings, our premium bearings have a 113 percent increase in calculated life and 25 percent more calculated load capacity.

For tough industrial applications, Timken designed a durable housing built with corrosion-resistant electrocoating, locking collars and Timken-designed double-lip seals.

Our seal improves grease retention and our rotating collar acts as an initial flinger. Together, they significantly block contaminant ingress and improve your operations.

Updates are made periodically to this catalog. Visit [www.timken.com](http://www.timken.com) for the most recent version of the Timken® Housed Unit Catalog.

### TYPICAL INDUSTRIES AND APPLICATIONS

Common uses include processing and material handling equipment found in many industries, including pulp and paper, power generation, mining, cement and aggregate. Type E housed units also are widely used in equipment used for air-handling, and water and waste-water treatment. Other common machine applications include mixers, washers, shredders, mills and oven/furnace roller beds.

Introduction.....	B-2
Engineering.....	B-5
Type E Product Data Tables.....	B-15
Nomenclature.....	B-16

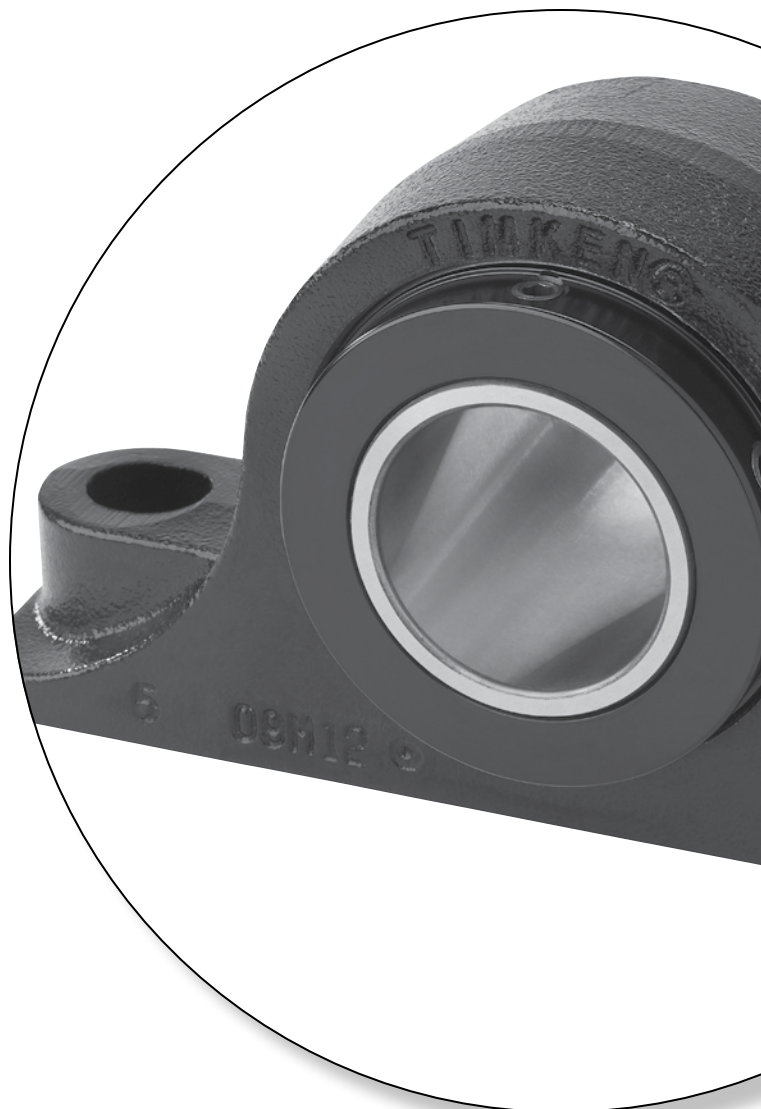

### INTRODUCTION

#### ENHANCED PERFORMANCE BEARINGS, LOWER COST OF OWNERSHIP

Timken Type E tapered roller bearings have a significantly higher load-carrying capability than industry-standard Type E housed units.

Our Type E bearings also experience lower internal contact stresses and frictional drag due to optimized bearing profiles and improved surface textures. This results in improved lubrication performance and up to three times greater misalignment capability than industry-standard tapered roller bearing designs.

Timken-designed double-lip seals help lower maintenance costs. The seals in our Type E housed units optimize lip contact to help improve grease retention and significantly reduce contaminant ingress.

#### SIZE RANGE AND CONFIGURATION

Timken Type E roller bearing housed units are available in a wide variety of sizes and configurations.

**TABLE B-1. SHAFT SIZES AND RANGES**

Housed Unit Configuration	Inches (in.)	Metric (mm)
Pillow Block: Two-Bolt Base	1 3/16 thru 3 1/2	35 thru 90
Pillow Block: Four-Bolt Base	2 1/4 thru 5	60 thru 125
Flange: Four-Bolt	1 3/16 thru 4 1/2	35 thru 115
Flange: Piloted	1 3/16 thru 5	35 thru 125
Take-Up: Wide Slot	1 3/8 thru 3	35 thru 75
Take-Up: Top Angle	1 3/4 thru 4	45 thru 100

#### European REACH Compliance

Timken lubricants, greases and similar products sold in stand-alone containers or delivery systems are subject to the European REACH (Registration, Evaluation, Authorization and Restriction of CHemicals) directive. For import into the European Union, Timken can sell and provide only those lubricants and greases that are registered with ECHA (European CHemical Agency). For further information, please contact your Timken engineer.

**WARNING**

***Failure to observe the following warnings could create a risk of death or serious injury.***

Proper maintenance and handling practices are critical. Failure to follow selection recommendations and installation instructions and to maintain proper lubrication can result in equipment failure.

Overheated bearings can ignite explosive atmospheres. Special care must be taken to properly select, install, maintain, and lubricate housed unit bearings that are used in or near atmospheres that may contain explosive levels of combustible gases or accumulations of dust such as from grain, coal, or other combustible materials. Consult your equipment designer or supplier for installation and maintenance instructions.

**CAUTION**

***Failure to follow these cautions could create a risk of injury.***

Do not use damaged housed units. The use of a damaged housed unit can result in equipment damage and/or injury.

**CAUTION**

***Failure to follow these cautions may result in property damage.***

If hammer and bar are used for installation or removal of a part, use a mild steel bar (e.g., 1010 or 1020 grade). Mild steel bars are less likely to cause release of high-speed fragments from the hammer, bar or the part being removed.

**NOTE**

*Do not use excessive force when mounting or dismounting the unit.*

*Follow all tolerance, fit, and torque recommendations.*

*Always follow the Original Equipment Manufacturer's installation and maintenance guidelines.*

*Ensure proper alignment.*

*Never weld housed units.*

*Do not heat components with an open flame.*

*Do not operate at bearing temperatures above 121° C (250° F).*

**DISCLAIMER**

***This catalog is provided solely to give you analysis tools and data to assist you in your product selection. Product performance is affected by many factors beyond the control of Timken. Therefore, you must validate the suitability and feasibility of all product selections for your applications.***

***Timken products are sold subject to Timken terms and conditions of sale, which include our limited warranty and remedy. You can find these at <http://www.timken.com/en-us/purchase/Pages/TermsandConditionsofSale.aspx>.***

***Please consult with your Timken engineer for more information and assistance.***

***Every reasonable effort has been made to ensure the accuracy of the information in this writing, but no liability is accepted for errors, omissions or for any other reason.***

**Updates are made periodically to this catalog. Visit [www.timken.com](http://www.timken.com) for the most recent version of the Timken® Housed Unit Catalog.**

**Warnings for this product line are in this catalog and posted on [www.timken.com/en-us/products/warnings/Pages/TimkenHousedUnitWarnings.aspx](http://www.timken.com/en-us/products/warnings/Pages/TimkenHousedUnitWarnings.aspx).**

### BENEFITS AND FEATURES

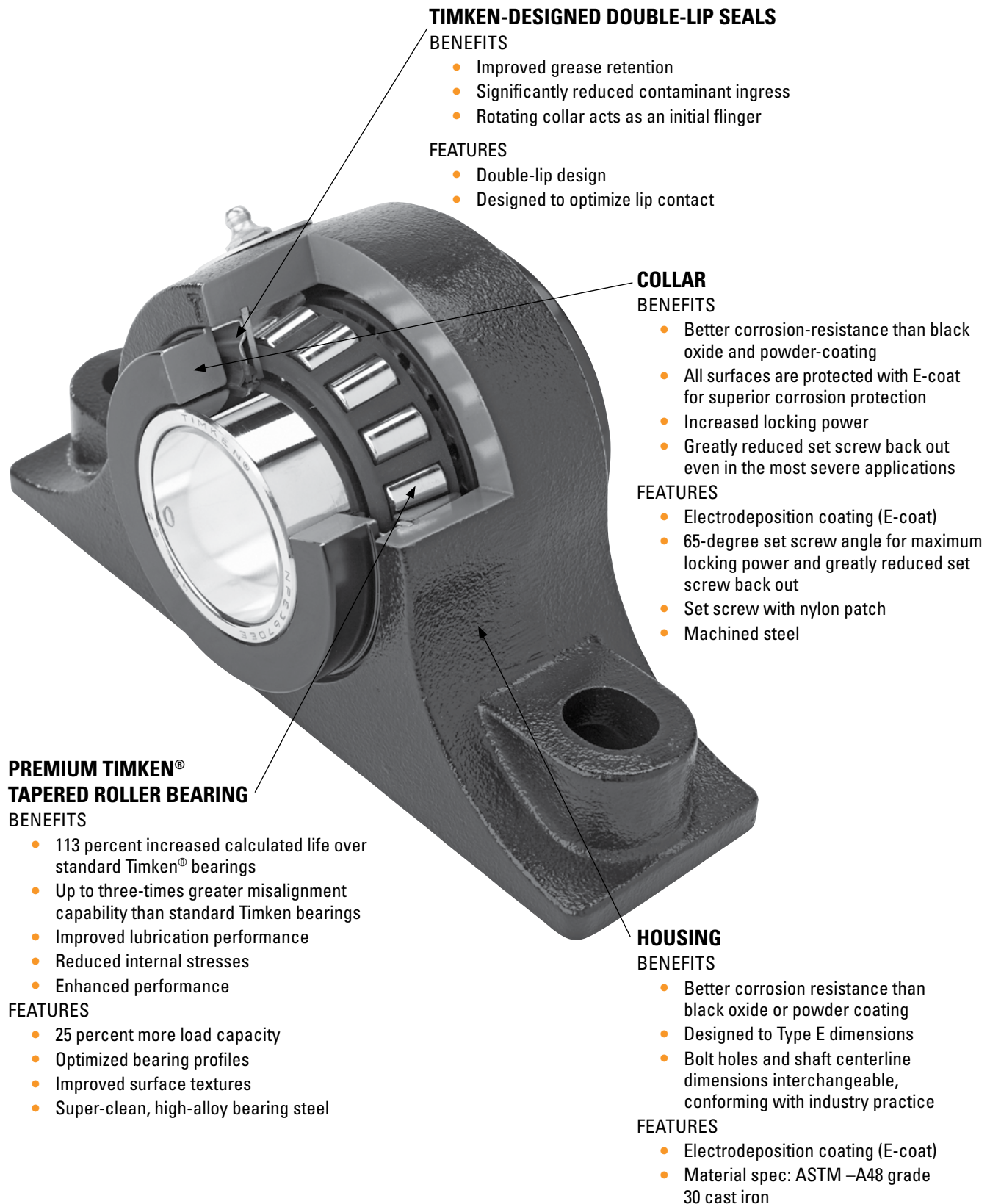

#### TIMKEN-DESIGNED DOUBLE-LIP SEALS

##### BENEFITS

- Improved grease retention
- Significantly reduced contaminant ingress
- Rotating collar acts as an initial flinger

##### FEATURES

- Double-lip design
- Designed to optimize lip contact

#### COLLAR

##### BENEFITS

- Better corrosion-resistance than black oxide and powder-coating
- All surfaces are protected with E-coat for superior corrosion protection
- Increased locking power
- Greatly reduced set screw back out even in the most severe applications

##### FEATURES

- Electrodeposition coating (E-coat)
- 65-degree set screw angle for maximum locking power and greatly reduced set screw back out
- Set screw with nylon patch
- Machined steel

#### PREMIUM TIMKEN® TAPERED ROLLER BEARING

##### BENEFITS

- 113 percent increased calculated life over standard Timken® bearings
- Up to three-times greater misalignment capability than standard Timken bearings
- Improved lubrication performance
- Reduced internal stresses
- Enhanced performance

##### FEATURES

- 25 percent more load capacity
- Optimized bearing profiles
- Improved surface textures
- Super-clean, high-alloy bearing steel

#### HOUSING

##### BENEFITS

- Better corrosion resistance than black oxide or powder coating
- Designed to Type E dimensions
- Bolt holes and shaft centerline dimensions interchangeable, conforming with industry practice

##### FEATURES

- Electrodeposition coating (E-coat)
- Material spec: ASTM –A48 grade 30 cast iron

## **ENGINEERING**

Tapered roller bearings can manage broad ranges of speed and many combinations of radial and thrust loads. Other important environmental conditions affect bearing operation, such as low and high temperature, dust and dirt, moisture and unusual mounting conditions.

This engineering section is not intended to be comprehensive, but does serve as a useful guide when selecting Type E housed units.

To view the complete engineering catalog, please visit [www.timken.com](http://www.timken.com). To order the catalog, please contact your Timken engineer and request a copy of the Timken Engineering Manual, order number 10424.

Bearing Selection and Life Calculations .....	B-6
Load and Speed Rating Tables .....	B-9
Installation and Lubrication .....	B-12



### BEARING SELECTION AND LIFE CALCULATIONS

Many different performance criteria exist that dictate how a bearing should be selected. These criteria include bearing fatigue life, rotational precision, power requirements, temperature limits, speed capabilities, sound and more. The life can also be limited by other system components such as the shaft, shaft interface and the housing. This section deals primarily with bearing life as related to material associated fatigue.

#### BEARING LIFE

Bearing life is defined here as the length of time, or number of revolutions, until a fatigue spall of 6 mm<sup>2</sup> (0.01 in.<sup>2</sup>) develops. Since metal fatigue is a statistical phenomenon, the life of an individual bearing is impossible to precisely predetermine. Bearings that may appear to be identical can exhibit considerable life scatter when tested under identical conditions. Thus, it is necessary to base life predictions on a statistical evaluation of a large number of bearings operating under similar conditions. The Weibull distribution function is commonly used to predict the life of a population of bearings at any given reliability level.

#### RATING LIFE

Rating life, (L<sub>10</sub>), is the life that 90 percent of a group of apparently identical bearings will complete or exceed before a fatigue spall develops. The L<sub>10</sub> life also is associated with 90 percent reliability for a single bearing under a certain load.

#### BEARING LIFE EQUATIONS

The L<sub>10</sub> life has been calculated as follows for bearings under radial or combined loading where the dynamic equivalent radial load, (P<sub>r</sub>), has been determined.

Tapered roller bearings often use a dynamic load rating (C<sub>90</sub>) based on 90 million cycles, yielding the equations as follows:

$$L_{10} = \left( \frac{C_{90}}{P_r} \right)^{10/3} (90 \times 10^6) \text{ revolutions}$$

or based on shaft speed, (RPM),

$$L_{10} = \left( \frac{C_{90}}{P_r} \right)^{10/3} \left( \frac{90 \times 10^6}{60n} \right) \text{ hours}$$

Timken has expanded standard life equations to include certain additional variables that can affect bearing performance. The approach that considers these factors in bearing analysis and selection has been termed Bearing Systems Analysis (BSA).

The Timken expanded bearing life equation for tapered roller bearings is:

$$L_{10a} = a_1 a_2 a_{3d} a_{3k} a_{3l} a_{3m} a_{3p} \left( \frac{C_{90}}{P_r} \right)^{10/3} \left( \frac{90 \times 10^6}{60n} \right) \text{ hours}$$

Where,

- a<sub>1</sub> = Reliability life factor
- a<sub>2</sub> = Material life factor
- a<sub>3d</sub> = Debris life factor
- a<sub>3k</sub> = Load zone life factor
- a<sub>3l</sub> = Lubrication life factor
- a<sub>3m</sub> = Misalignment life factor
- a<sub>3p</sub> = Low-load life factor

More details on Life Adjustment Factors can be found in the Timken Engineering Manual (order no. 10424) available on [timken.com](http://timken.com) or by contacting a Timken engineer.

Other factors that can be taken into account within the simple bearing life equation are shock or vibration. These are known to occur in many industrial applications due to combined factors including imbalanced dynamic forces, abusive handling, equipment misuse or neglect. These are difficult to predict.

When these conditions are known or suspected to occur, we suggest that equipment designers use a multiplication factor of (1.5 x P<sub>r</sub>) to estimate effects on housed unit selection and system reliability. Performance testing or advanced analysis is strongly suggested to validate final product selection.

## TIMKEN® ROLLER HOUSED UNIT SELECTION

The double extended tapered roller bearings used in the Type E roller housed units are suited for carrying radial, thrust or a combination of both types of loading. This section will describe the bearing selection process using different methods based on selection criteria and application details.

### METHOD 1 – SELECTION TABLE (RADIAL LOADS ONLY)

Note: Based on reference conditions with adequate lubrication.

- Determine criteria for bearing selection:
  - $L_{10}$  life required.
  - Size of bearing based on shaft size (if known).
  - Loading conditions (radial) of the application.
  - Shaft speed measured by revolutions per minute (RPM).
- Use table B-3:
  - Find speed criteria on upper row.
  - Proceed in the column directly below that speed to the equivalent radial load ( $P_r$ ) that is equal to or greater than that required.
  - Follow that row to the left to determine what the minimum shaft size should be for the required  $L_{10}$  life (hours). Many values are listed to help in selecting the proper bearing.

### METHOD 2 – USING BEARING LIFE EQUATION TO SELECT BEARING FOR A DIFFERENT $L_{10}$ LIFE (RADIAL LOADS ONLY)

If a different life is required than what is found in table B-3, it can be calculated from the bearing life equation. Note that each value in the selection table was calculated using this equation. The equation can be rewritten based on the unknown value.

Take the bearing life equation shown previously:

$$L_{10} = \left( \frac{C_{90}}{P_r} \right)^{10/3} \left( \frac{90 \times 10^6}{60n} \right) \text{ hours}$$

Or rewritten as:

$$L_{10} = \left( \frac{C_{90}}{P_r} \right)^{10/3} \left( \frac{1500000}{n} \right) \text{ hours}$$

Solve for  $C_{90}$ :

$$C_{90} = \left( \frac{L_{10} \times n}{1500000} \right)^{0.3} \left( P_r \right)$$

After calculating the  $C_{90}$ , check table B-3 to determine the shaft size needed. (Note: Ensure that the application speed does not exceed the maximum RPM found on that same table). Check the radial load, as well, with regard to the maximum allowable slip-fit radial load ( $F_{r-max}$ , see table B-5). If this value is exceeded, then a tighter line-to-line or press fit is required.

### TIMKEN METHOD 3A – DETERMINE EQUIVALENT RADIAL LOADS AND USE BEARING LIFE EQUATION (FOR COMBINED RADIAL- AND THRUST-LOADED APPLICATIONS)

For combined radial- and thrust-loaded applications, it is necessary to calculate an equivalent dynamic radial bearing load, designated by  $P_r$ , before applying the  $L_{10}$  bearing life equation. The dynamic equivalent radial load is defined as a single radial load that, if applied to the bearing, will result in the same life as the combined loading under which the bearing operates.

Tapered roller bearings are ideally suited to carrying all types of loads – radial, thrust and any combination of both. Due to the tapered design of the bearing, a radial load will induce a thrust reaction that must be opposed by an equal or greater thrust load to keep the bearing cone and cup from separating.

The ratio of the radial to the thrust load and the bearing included cup angle determine the load zone in a given bearing and the number of rollers in contact in the load zone in the bearing. If all the rollers are in contact, the load zone is referred to as being 360 degrees. When only radial load is applied to a tapered roller bearing – for convenience it is assumed in using the traditional calculation method that half the rollers support the load – the load zone is 180 degrees.

For Type E roller housed units with no external thrust load ( $F_a = 0$ ), the dynamic equivalent radial load ( $P_r$ ) equals  $F_r$ . This  $P_r$  value can then be used in the bearing life equation shown on page B-6.

For Type E units with thrust loading, table B-2 can be used. In this table, only bearing A has an applied thrust load. If bearing B has the applied thrust load, each A in the equations should be replaced by a B and vice versa.

The equations in the first row of table B-2 yield single-row equivalent radial loads ( $P_{rA}$  and  $P_{rB}$ ). To find the two-row (Type E housed unit) life, the following equations must be used to solve for  $L_{10}$  life of each bearing row, and then combined for the system unit life:

$$L_{10A} = \left( \frac{C_{90}}{1.74 \times P_{rA}} \right)^{10/3} \left( \frac{1500000}{n} \right) \text{ hours}$$

and,

$$L_{10B} = \left( \frac{C_{90}}{1.74 \times P_{rB}} \right)^{10/3} \left( \frac{1500000}{n} \right) \text{ hours}$$

then,

$$L_{10} = \left[ \left( \frac{1}{L_{10A}} \right)^{3/2} + \left( \frac{1}{L_{10B}} \right)^{3/2} \right]^{-2/3} \text{ hours}$$

In the second row of table B-2,  $P_{rB} = 0$ ; therefore,  $P_{rA} = P_r$  in the standard bearing life equation shown on page B-6.

### ISO METHOD 3B

The ISO Method uses the following equation to determine the equivalent dynamic radial load:

$$P_r = XF_r + YF_a$$

Where,

$P_r$  = Dynamic equivalent radial load

$F_r$  = Applied radial load

$F_a$  = Applied axial load

$X$  = Radial load factor

$Y$  = Axial load factor

The values for  $X$  and  $Y$  are found in table B-5. In order to find these values, the value of  $F_r/F_a$  must be compared to the  $e$  value. Determine if the value is greater than or less than the  $e$  and then use the corresponding  $X$  and  $Y$  values below that formula.

After the  $P_r$  value is calculated, then use the bearing life equation as shown on page B-6.

### ISO METHOD 4 – (THRUST ONLY APPLICATIONS)

Use the equation  $P_r = YF_a$ . Use  $Y$  from table B-5 (for  $F_a/F_r > e$ ). Then use this  $P_r$  value for the equivalent radial load in the bearing life equation. This value can also be used as the radial load in the load rating selection table B-3.

After selection has been made, verify that the application does not exceed the maximum allowable speed, allowable thrust loads and allowable housing loads. Heavy loads should be directed through the base of the units. See table B-4 for housing ratings for loads applied upward through the top of the housed unit perpendicular to the shaft axis. The housings need to be bolted down with adequate strength.

**TABLE B-2. DYNAMIC EQUIVALENT RADIAL LOAD CALCULATIONS**

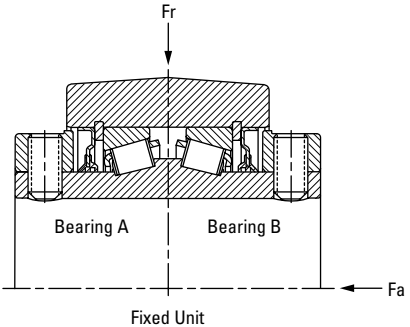
Design	Thrust Condition	Dynamic Equivalent Radial Load
	$F_a \leq \frac{0.6 F_r}{K}$	$P_{rA} = 0.5 F_r + 0.83 K F_a$ $P_{rB} = 0.5 F_r - 0.83 K F_a$
	$F_a > \frac{0.6 F_r}{K}$	$P_{rA} = 0.4 F_r + K F_a$ $P_{rB} = 0$

## LOAD AND SPEED RATING TABLES

The table below shows the allowable equivalent radial load for a given shaft size, speed, and  $L_{10}$  life under normal operating conditions with adequate lubrication. Refer to the discussion on the previous pages of this catalog to determine the criteria for combinations not shown in this table or for combined load applications.

### NOTE

The shaded area in this table indicates radial loads that exceed the maximum allowable slip-fit radial load ( $F_{r-max}$ ). Operation at these conditions may require line-to-line (g6 or h6) or light press fit (m6) on the shaft.

TABLE B-3. TYPE E TAPERED ROLLER BEARING LOAD RATING SELECTION TABLE

Shaft Dia.	Basic Dynamic Load Rating $C_{90}$	Max Speed Timken Double-Lip Seal RPM	Life $L_{10}$ hrs.	Equivalent Radial Loads Allowed, $P_r$ at Various Speeds, RPM																		
				50	100	150	250	500	750	1000	1200	1360	1530	1640	1750	2060	2420	2730	3050	3320	3820	4490
in. mm	lbs.	RPM	hrs.	lbs.	lbs.	lbs.	lbs.	lbs.	lbs.	lbs.	lbs.	lbs.	lbs.	lbs.	lbs.	lbs.	lbs.	lbs.	lbs.	lbs.	lbs.	
1 3/16 1 1/4	3810	4490	10000	5297	4303	3810	3269	2655	2351	2157	2042	1966	1898	1859	1823	1736	1654	1596	1543	1505	1443	1374
			30000	3810	3095	2740	2351	1910	1691	1551	1468	1414	1365	1337	1311	1249	1190	1148	1110	1082	1038	988
			40000	3495	2839	2514	2157	1752	1551	1423	1347	1297	1252	1227	1203	1145	1091	1053	1018	993	952	907
			60000	3095	2514	2226	1910	1551	1373	1260	1193	1149	1109	1086	1065	1014	966	932	902	879	843	803
1 3/8 1 7/16 35 mm	6100	3820	10000	8481	6889	6100	5233	4251	3764	3453	3269	3148	3039	2976	2919	2780	2649	2555	2471	2409	2310	
			30000	6100	4955	4387	3764	3057	2707	2483	2351	2264	2186	2141	2099	1999	1905	1837	1777	1733	1661	
			40000	5596	4545	4024	3453	2804	2483	2278	2157	2077	2005	1964	1926	1834	1747	1685	1630	1589	1524	
			60000	4955	4024	3564	3057	2483	2199	2017	1910	1839	1775	1739	1705	1624	1547	1492	1444	1407	1349	
1 1/2 1 5/8 1 11/16 40 mm	7860	3320	10000	10928	8877	7860	6743	5477	4850	4449	4212	4057	3916	3835	3761	3582	3413	3292	3184	3104		
			30000	7860	6384	5653	4850	3939	3488	3200	3029	2918	2816	2758	2705	2576	2455	2367	2290	2232		
			40000	7210	5856	5186	4449	3614	3200	2935	2779	2677	2584	2530	2482	2363	2252	2172	2101	2048		
			60000	6384	5186	4592	3939	3200	2833	2599	2461	2370	2288	2241	2197	2092	1994	1923	1860	1813		
1 3/4 1 7/8 1 15/16 2 45 mm 50 mm	10300	3050	10000	14321	11632	10300	8837	7178	6355	5830	5520	5316	5132	5026	4929	4694	4472	4313	4172			
			30000	10300	8366	7408	6355	5162	4571	4193	3970	3824	3691	3615	3545	3376	3217	3102	3001			
			40000	9448	7674	6795	5830	4735	4193	3846	3642	3507	3386	3316	3252	3097	2951	2846	2753			
			60000	8366	6795	6017	5162	4193	3713	3406	3225	3106	2998	2936	2879	2742	2613	2520	2437			
2 3/16 55 mm	10900	2730	10000	15155	12310	10900	9351	7596	6726	6170	5841	5626	5431	5319	5216	4967	4733	4565				
			30000	10900	8854	7840	6726	5463	4837	4437	4201	4046	3906	3825	3752	3572	3404	3283				
			40000	9999	8121	7191	6170	5011	4437	4070	3854	3712	3583	3509	3441	3277	3122	3012				
			60000	8854	7191	6368	5463	4437	3929	3604	3412	3287	3172	3107	3047	2902	2765	2667				
2 1/4 2 7/16 2 1/2 60 mm 65 mm	11600	2420	10000	16129	13100	11600	9952	8083	7158	6566	6216	5987	5779	5660	5551	5286	5037					
			30000	11600	9422	8343	7158	5814	5148	4722	4471	4306	4157	4071	3992	3802	3622					
			40000	10641	8643	7653	6566	5333	4722	4332	4101	3950	3813	3734	3662	3487	3323					
			60000	9422	7653	6777	5814	4722	4181	3836	3631	3498	3376	3307	3243	3088	2942					
2 11/16 2 3/4 2 15/16 3 70 75	12300	2060	10000	17102	13891	12300	10552	8571	7590	6962	6591	6348	6128	6002	5886	5605						
			30000	12300	9991	8846	7590	6165	5459	5007	4741	4566	4407	4317	4233	4031						
			40000	11283	9165	8115	6962	5655	5007	4593	4349	4188	4043	3960	3883	3698						
			60000	9991	8115	7186	6165	5007	4434	4067	3851	3709	3580	3506	3439	3274						
3 3/16 3 1/4 3 7/16 3 1/2 80 mm 85 mm 90 mm	19600	1640	10000	27252	22135	19600	16815	13658	12094	11094	10503	10116	9765	9564								
			30000	19600	15920	14097	12094	9823	8698	7979	7554	7276	7023	6879								
			40000	17979	14604	12931	11094	9011	7979	7319	6930	6674	6443	6310								
			60000	15920	12931	11450	9823	7979	7065	6481	6136	5910	5705	5587								
100000	13658	11094	9823	8428	6845	6061	5560	5264	5070	4894	4793											

Continued on next page.

**LOAD AND SPEED RATING TABLES** – continued

**TABLE B-3. TYPE E TAPERED ROLLER BEARING LOAD RATING SELECTION TABLE** – Continued from previous page.

Shaft Dia.	Basic Dynamic Load Rating C <sub>90</sub>	Max Speed Timken Double-Lip Seal RPM	Life L <sub>10</sub>	Equivalent Radial Loads Allowed, P, at Various Speeds, RPM																				
				50	100	150	250	500	750	1000	1200	1360	1530	1640	1750	2060	2420	2730	3050	3320	3820	4490		
in. mm	lbs.	RPM	hrs.	lbs.	lbs.	lbs.	lbs.	lbs.	lbs.	lbs.	lbs.	lbs.	lbs.	lbs.	lbs.	lbs.	lbs.	lbs.	lbs.	lbs.	lbs.			
3 15/16 4 100 mm	26900	1530	10000	37401	30379	26900	23078	18745	16598	15226	14415	13884	13402											
			30000	26900	21850	19347	16598	13482	11938	10951	10368	9986	9639											
			40000	24676	20043	17747	15226	12367	10951	10045	9511	9160	8842											
			60000	21850	17747	15715	13482	10951	9697	8895	8421	8111	7829											
			100000	18745	15226	13482	11566	9395	8319	7631	7225	6959	6717											
4 7/16 4 1/2 110 mm 115 mm	33000	1360	10000	45883	37268	33000	28311	22996	20362	18678	17684	17033												
			30000	33000	26804	23734	20362	16539	14645	13434	12719	12250												
			40000	30271	24588	21772	18678	15172	13434	12323	11667	11237												
			60000	26804	21772	19278	16539	13434	11895	10912	10331	9950												
			100000	22996	18678	16539	14189	11525	10205	9361	8863	8536												
4 15/16 5 125 mm	45500	1200	10000	63263	51385	45500	39035	31706	28075	25754	24383													
			30000	45500	36957	32725	28075	22804	20192	18523	17537													
			40000	41738	33902	30019	25754	20918	18523	16991	16087													
			60000	36957	30019	26581	22804	18523	16401	15045	14244													
			100000	31706	25754	22804	19564	15891	14071	12907	12220													

**HOUSING RATINGS**

**TABLE B-4. HOUSING RATINGS – TYPE E PILLOW BLOCKS: TWO-BOLT BASE, FOUR-BOLT BASE**

Shaft Dia.	Maximum Housing Rating Gray Iron at 180°
in. mm	lbs.
1 3/16 thru 1 1/4	1600
1 3/8 thru 1 7/16 35	3150
1 1/2 thru 1 11/16 40	3000
1 3/4 thru 2 45 thru 50	5150
2 3/16 55	3500
2 1/4 thru 2 1/2 60 thru 65	6550
2 11/16 thru 3 70 thru 75	7000
3 3/16 thru 3 1/2 80 thru 90	15700
3 15/16 thru 4 100	16250
4 7/16 thru 4 1/2 110 thru 115	21000
4 15/16 thru 5 125	22860

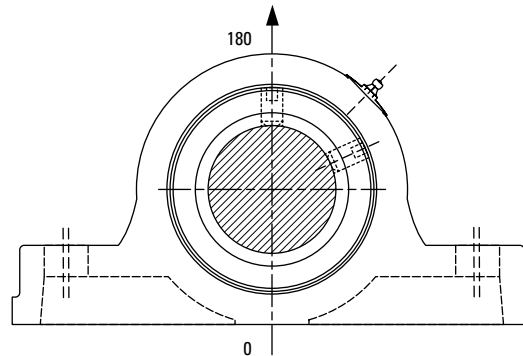

1. These ratings have been calculated for initial bearing selection. These include a nominal safety factor for the standard Type E two- and four-bolt pillow blocks. The following conditions apply: standard cast-iron material, the force is applied perpendicular to the shaft axis, and the housing bolts are properly clamped.
2. These limits should not be applied to operating conditions that include impact (shock) loads or combined radial and thrust loads that are not directed into the pillow block base.
3. If heavy cap loads are expected, use the following modifications to mounting method or equipment design: Grade 8 base bolts and hardened washers; ensure that proper installation torque is achieved and is uniform.
4. If axial loads are expected, provide mechanical stops or shear bars with strength sufficient to support the load. Specification of the strength, material, method of fastening, and precision location are the responsibility of the machinery designer.

TABLE B-5. TAPERED ROLLER BEARING – RADIAL AND THRUST FACTORS; SPEED AND SLIP-FIT LOAD LIMITS

Shaft Dia.	e	$F_a / F_r \leq e$		$F_a / F_r > e$		K Factor	Dynamic Load Rating <sup>(1)</sup> C <sub>90</sub>	Static Load Rating C <sub>0</sub>	Maximum Permissible Thrust Load <sup>(2)</sup> F <sub>a-max</sub>	Max Speed <sup>(3)</sup> RPM	Maximum Allowable Slip-Fit Radial Load <sup>(4)</sup> F <sub>r-max</sub>
		X	Y	X	Y						
in. mm							lbs.	lbs.	lbs.		lbs.
1 3/16 1 1/4	0.49	0.87	1.77	0.70	2.14	1.23	3810	15760	2000	4490	3100
1 3/8 1 7/16 35 mm	0.46	0.87	1.89	0.70	2.28	1.31	6100	26000	2590	3820	5000
1 1/2 1 5/8 1 11/16 40 mm	0.44	0.87	1.96	0.70	2.37	1.36	7860	33000	2590	3320	6400
1 3/4 1 7/8 1 15/16 2 45 mm 50 mm	0.33	0.87	2.64	0.70	3.18	1.83	10300	43000	2590	3050	8400
2 3/16 55 mm	0.36	0.87	2.38	0.70	2.87	1.65	10900	48200	3454	2730	8900
2 1/4 2 7/16 2 1/2 60 mm 65 mm	0.4	0.87	2.17	0.70	2.63	1.51	11600	54000	3454	2420	9500
2 11/16 2 3/4 2 15/16 3 70 mm 75 mm	0.46	0.87	1.87	0.70	2.26	1.3	12300	61200	5181	2060	10000
3 3/16 3 1/4 3 7/16 3 1/2 80 mm 85 mm 90 mm	0.5	0.87	1.71	0.70	2.07	1.19	19600	108600	5181	1640	16000
3 15/16 4 100 mm	0.49	0.87	1.77	0.70	2.14	1.23	26900	154000	6908	1530	22000
4 7/16 4 1/2 110 mm	0.53	0.87	1.63	0.70	1.97	1.13	33000	188400	6908	1360	27000
4 15/16 5 125 mm	0.47	0.87	1.83	0.70	2.21	1.27	45500	266000	6908	1200	35000

<sup>(1)</sup>C<sub>90</sub> is the dynamic load rating based on a rated life of 90 million revolutions (3000 hrs. at 500 RPM).

<sup>(2)</sup>F<sub>a-max</sub> is based on the limits of the holding force of two properly tightened collars and set screws. When a single collar is installed, 50 percent of the values should be used.

<sup>(3)</sup>Double-lip seal.

<sup>(4)</sup>Operating at conditions where loads approach or exceed F<sub>r-max</sub> may require line-to-line (g6 or h6) or light press-fit (m6) on the shaft.

NOTE: The maximum permissible thrust load applies to conditions of slip-fit with set screw mounting or in applications where a large moment loading occurs. The values shown are valid only when two collars and set screws are used.

NOTE: When heavy thrust forces are applied, the friction between the pillow block and base may not be sufficient to prevent movement. Mechanical stops or shear bars with strength sufficient to support the load should be added. Never weld the pillow block or bearing to secure it to the shaft or base.

## INSTALLATION AND LUBRICATION

### INSTALLATION

**Proper installation of the housed unit is necessary.** This includes the use of shafts that are clean, free from nicks and burrs, straight and of proper diameter. Follow table B-6. The recommended shaft tolerances shown in table B-6 are for normal loaded applications. Refer to table B-5 to verify the maximum allowable slip-fit radial load ( $F_{r-max}$ ) and to determine if a tighter fit is required.

Do not mount the bearing on a worn section of the shaft. Use of shafts with hardness greater than HRC 45 will reduce the effectiveness of locking devices.

Also, it is necessary that the housed units and shafts are in alignment (fig. B-3). Verify that the mounting surfaces are in the same flat plane to help make sure good alignment is achieved. If shimming is required to minimize misalignment, use full shims across the entire housing base (fig. B-4). The bolts then need to be alternately torqued securely to their mounting supports.

Flat washers should be used when installing any kind of housed unit (fig. B-4). Washers should be properly sized to the bolt diameter. Typically, the diameters of SAE washers are too small to properly cover the bolt slots on the units. After the locking collars are lined up flush with the end of the cone (inner ring) face (fig. B-5), set screws then need to be properly tightened per table B-7. Set screws in multiple units should be aligned to each other (fig. B-6).

### LUBRICATION

To help maintain a rolling bearing's antifriction characteristics, lubrication is needed to:

- Minimize rolling resistance due to deformation of the rolling elements and raceway under load by separating the mating surfaces.
- Minimize sliding friction occurring between rolling elements, raceways and cage.
- Protect from corrosion and, with grease lubrication, from contaminant ingress.

Bearings have been factory prelubricated with Timken Premium All Purpose Industrial Grease, which is an NLGI No. 2 lithium-complex-based grease. This is suitable for normal operating conditions. Units should be relubricated with the Timken grease or one that is compatible and made for roller bearings.

**It is vital that the greases used are compatible. Please consult with a Timken engineer for the grease specifications if the use of a grease other than the Timken grease mentioned above is needed.**

Normal service is considered as operation in a clean, dry environment at temperatures between  $-34^{\circ}\text{C}$  to  $+82^{\circ}\text{C}$  ( $-30^{\circ}\text{F}$  and  $+180^{\circ}\text{F}$ ). If service is beyond normal conditions due to speed, temperature or exposure to moisture, dirt or corrosive chemicals, periodic relubrication may be advisable. For extreme conditions or conditions in which special chemicals are used, consult your Timken engineer.

After extended storage or periods when the unit is not in operation, fresh grease should be added.

For units operating in dirty or wet environments, the bearing should contain as much grease as possible, based on the shaft speed, to help protect against contamination. For slower applications, with shaft speeds typically less than 200 RPM, the unit should have additional grease added at start-up to fill the bearing.

Lubrication affects the bearing operating temperature as well. If the bearing does not have enough grease, this could lead to higher temperature operation due to inadequate lubrication film thickness. Excessive grease will lead to higher operating temperatures due to grease churning. This can cause bearing overheating. To avoid this, it may be necessary to remove some of the grease inside the unit. The grease fitting may be removed briefly in this circumstance to allow excess grease to purge. The grease fitting must be put back in place. It is best to observe the bearing and its temperature to adjust the lubrication as needed.

### RELUBRICATION CYCLE

Adequate lubrication is an essential element affecting the bearing life. The two primary considerations that determine the relubrication cycle on any application are operating temperature and contamination. Every attempt should be made to maintain seals at peak efficiency.

The higher the temperature, the more rapidly the grease oxidizes. Grease life is reduced by approximately half for every  $10^{\circ}\text{C}$  ( $18^{\circ}\text{F}$ ) rise in temperature. The higher the operating temperature, the more often the grease must be replenished. Table B-8 can be used as a suggested initial point of reference. Relubrication frequency and quantity intervals are best developed through experience for each application based on types of service, which may differ from the suggestions in table B-8.

When the bearing is not in operation for an extended period of time, grease should be added to prevent corrosion.

Table B-8 shows general lubrication suggested starting points only. Please read the entire installation instructions prior to using these tables. Applications should be regularly reviewed and lubrication amounts and intervals modified as needed to assure best results.

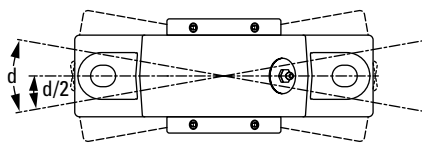

ALIGN HOUSING TO 1/2 TOTAL ANGULAR MOVEMENT.

Fig. B-3.

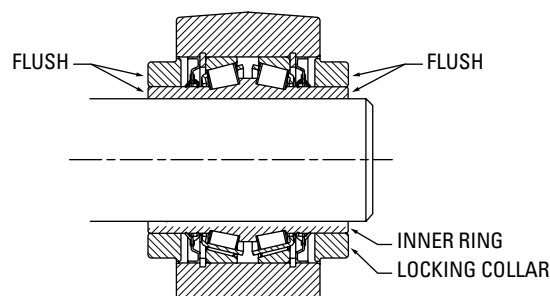

LINE UP COLLARS WITH INNER RING.

Fig. B-5.

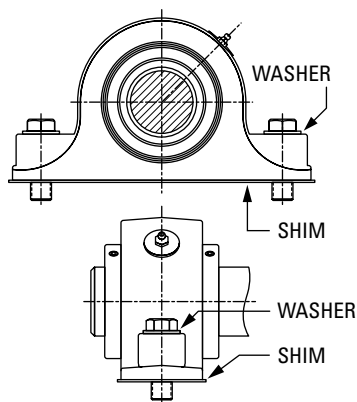

USE WASHERS AND FULL SHIMS.

Fig. B-4.

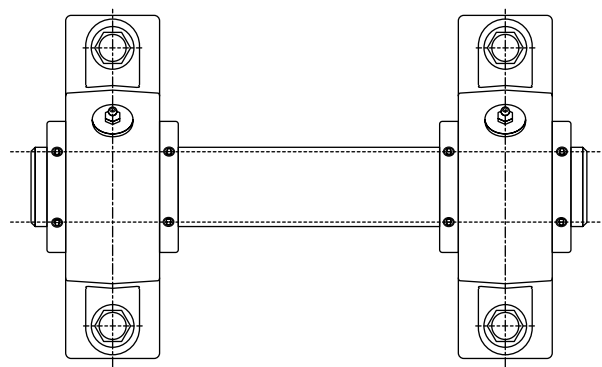

LINE UP SET SCREWS IN MULTIPLE UNITS.

Fig. B-6.

TABLE B-6. RECOMMENDED SHAFT TOLERANCE

Shaft Dia.	Tolerance
in. mm	in. mm
Up thru 1 1/2 35 mm	+0.0000 to -0.0005 <b>+0.000 to -0.013</b>
1 5/8 thru 4 40 thru 100 mm	+0.0000 to -0.0010 <b>+0.000 to -0.025</b>
4 7/16 thru 5 110 thru 125 mm	+0.0000 to -0.0015 <b>+0.000 to -0.038</b>

NOTE: Refer to the Timken Engineering Manual (order no. 10424) for ISO g6, h6 or m6 shaft tolerance data.

TABLE B-7. RECOMMENDED SET SCREW TIGHTENING TORQUE

Shaft Dia.	Set Screw Size	Tightening Torque
in. mm	in.	in. - lbs.
1 3/16 thru 1 11/16 35 thru 40 mm	5/16-18	155
1 3/4 thru 2 1/2 45 thru 65 mm	3/8-16	275
2 11/16 thru 3 1/2 70 thru 90 mm	1/2-13	615
3 15/16 thru 5 100 thru 125 mm	5/8-11	1315

**WARNING**

*Failure to observe the following warnings could create a risk of death or serious injury.*

Overheated bearings can ignite explosive atmospheres. Special care must be taken to properly select, install, maintain, and lubricate housed unit bearings that are used in or near atmospheres that may contain explosive levels of combustible gases or accumulations of dust such from grain, coal, or other combustible materials. Consult your equipment designer or supplier for installation and maintenance instructions.

TABLE B-8. SUGGESTED RELUBRICATION INTERVALS (BASED ON EIGHT HOURS/DAY OPERATION)

Environment	Clean: Un-Exposed			Moderate: Exposed			Extreme: Harsh		
	Low	Med.	Hi	Low	Med.	Hi	Low	Med.	Hi
Application Speed <sup>(1)</sup>									
Greasing Interval	1 year	2 months	2 weeks	1 month	2 weeks	<sup>(2)</sup>	1 week	1 week	<sup>(2)</sup>

<sup>(1)</sup>Low < 25% max RPM; 25% < Med. < 75%; 75% < Hi – See table B-5.

<sup>(2)</sup>Use extra caution due to heat generation.

Relubrication frequency and quantity are best developed through experience. At all times, follow Original Equipment Manufacturer's maintenance instructions.



***TYPE E TAPERED ROLLER BEARING  
HOUSED UNIT PRODUCT DATA TABLES***

The following tables include product specification information for Timken® Type E housed units. Contact your Timken engineer for more information.

Pillow Block: Two-Bolt Base .....	B-17
Pillow Block: Four-Bolt Base .....	B-18
Flange: Four-Bolt .....	B-19
Flange: Piloted .....	B-20
Take-Up: Wide Slot .....	B-21
Take-Up: Top Angle .....	B-22



**NOMENCLATURE**

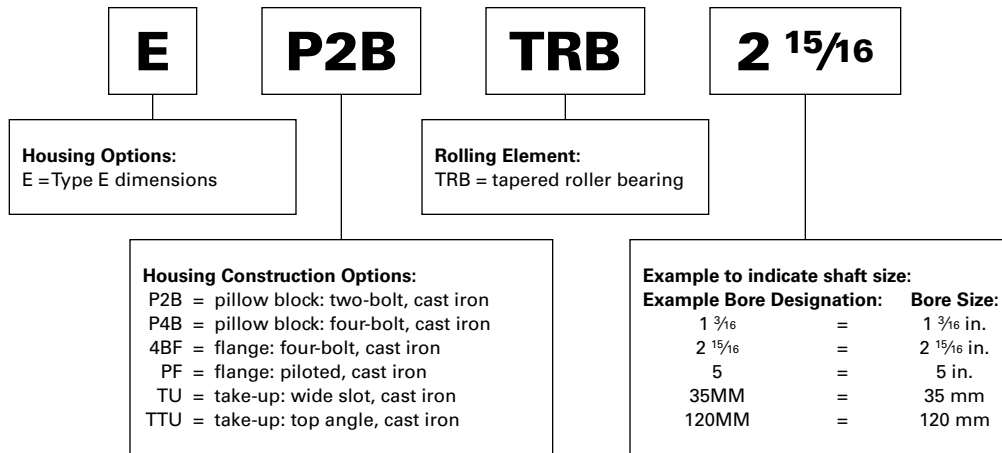
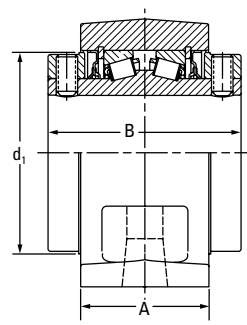
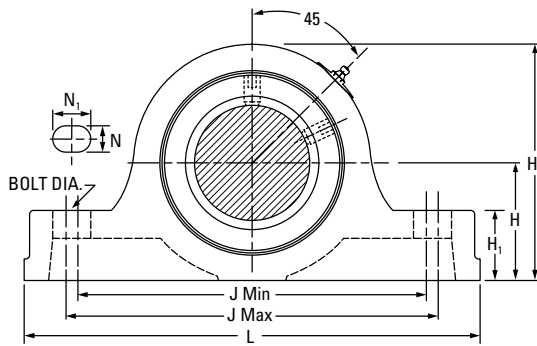

Fig. B-1. Type E nomenclature.

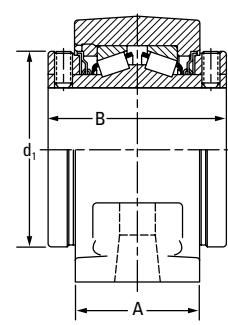

Fig. B-2. Type E housed unit types.

PILLOW BLOCK: TWO-BOLT BASE



1 1/16 IN. THRU 3 IN. SHAFT SIZE



3 3/16 IN. THRU 3 1/2 IN. SHAFT SIZE

Shaft Dia.	Part No.	B	L	A	J		Bolt Dia.	N	N <sub>1</sub>	H <sub>1</sub>	H <sub>2</sub>	d <sub>1</sub>	H	Approx. Wt.
					Max.	Min.								
in. mm		in.	in.	in.	in.	in.	in.	in.	in.	in.	in.	in.	in.	lbs.
1 13/16	E-P2B-TRB-1 3/16	2 3/4	6	1 7/8	4 13/16	4 3/4	1/2	9/16	19/32	7/8	3	2 1/4	1 1/2	4
1 1/4	E-P2B-TRB-1 1/4													
1 3/8	E-P2B-TRB-1 3/8													
1 7/16	E-P2B-TRB-1 7/16	3	7 3/8	2 1/8	5 7/8	5 5/8	1/2	5/8	3/4	1 1/8	3 3/4	2 3/4	1 7/8	7
35 mm	E-P2B-TRB-35MM													
1 1/2	E-P2B-TRB-1 1/2	3 3/8	7 7/8	2 3/8	6 3/8	6 1/8	1/2	5/8	3/4	1 1/4	4 1/4	3 3/16	2 1/8	10
1 5/8	E-P2B-TRB-1 5/8													
1 11/16	E-P2B-TRB-1 11/16													
40 mm	E-P2B-TRB-40MM													
1 3/4	E-P2B-TRB-1 3/4													
1 7/8	E-P2B-TRB-1 7/8	3 1/2	8 7/8	2 1/2	7 1/8	6 7/8	5/8	3/4	7/8	1 15/16	4 1/2	3 7/16	2 1/4	12
1 15/16	E-P2B-TRB-1 15/16													
2	E-P2B-TRB-2													
45 mm	E-P2B-TRB-45MM													
50 mm	E-P2B-TRB-50MM													
2 3/16	E-P2B-TRB-2 3/16	3 3/4	9 5/8	2 5/8	7 7/8	7 5/8	5/8	3/4	7/8	1 1/2	5	3 3/4	2 1/2	15
55 mm	E-P2B-TRB-55MM													
2 1/4	E-P2B-TRB-2 1/4													
2 7/16	E-P2B-TRB-2 7/16													
2 1/2	E-P2B-TRB-2 1/2													
60 mm	E-P2B-TRB-60MM	4	10 1/2	2 7/8	8 5/8	8 3/8	5/8	3/4	7/8	1 5/8	5 23/32	4 1/16	2 3/4	23
65 mm	E-P2B-TRB-65MM													
2 11/16	E-P2B-TRB-2 11/16													
2 3/4	E-P2B-TRB-2 3/4													
65 mm	E-P2B-TRB-65MM													
2 11/16	E-P2B-TRB-2 11/16	4 1/2	12	3	9 11/16	9 5/16	3/4	27/32	1	1 7/8	6 1/4	4 23/32	3 1/8	28
2 3/4	E-P2B-TRB-2 3/4													
2 15/16	E-P2B-TRB-2 15/16													
3	E-P2B-TRB-3													
70 mm	E-P2B-TRB-70MM													
75 mm	E-P2B-TRB-75MM	5	14	3 1/2	11 13/16	10 13/16	7/8	1	1 13/16	2 1/4	7 1/2	5 17/32	3 3/4	48
3 3/16	E-P2B-TRB-3 3/16													
3 1/4	E-P2B-TRB-3 1/4													
3 7/16	E-P2B-TRB-3 7/16													
3 1/2	E-P2B-TRB-3 1/2													
80 mm	E-P2B-TRB-80MM													
85 mm	E-P2B-TRB-85MM													
90 mm	E-P2B-TRB-90MM													

# TAPERED ROLLER BEARING TYPE E HOUSED UNITS

## PILLOW BLOCK: FOUR-BOLT BASE

### PILLOW BLOCK: FOUR-BOLT BASE

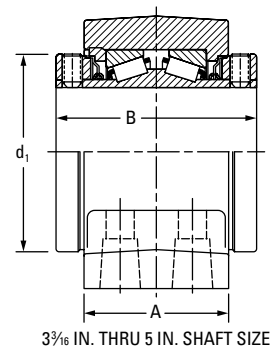
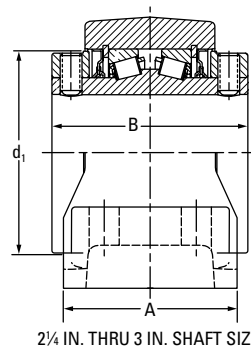
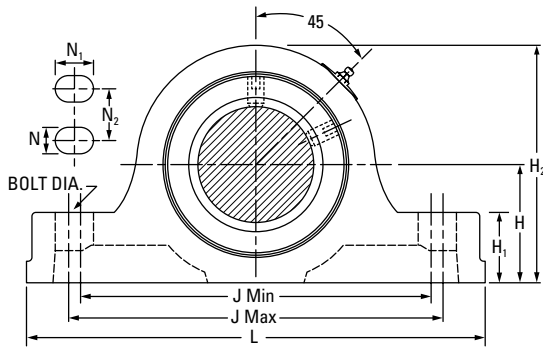

Shaft Dia. in. mm	Part No.	B in.	L in.	A in.	J		Bolt Dia. in.	N in.	N <sub>1</sub> in.	N <sub>2</sub> in.	H <sub>1</sub> in.	H <sub>2</sub> in.	d <sub>1</sub> in.	H in.	Approx. Wt. lbs.
					Max. in.	Min. in.									
2 1/4	E-P4B-TRB-2 1/4	4	10 1/2	3 1/2	8 11/16	8 5/16	5/8	11/16	7/8	1 7/8	1 5/8	5 23/32	4 1/16	2 3/4	22
2 7/16	E-P4B-TRB-2 7/16														22
2 1/2	E-P4B-TRB-2 1/2														21
60 mm	E-P4B-TRB-60MM														22
65 mm	E-P4B-TRB-65MM														21
2 11/16	E-P4B-TRB-2 11/16	4 1/2	12	4	9 13/16	9 3/16	5/8	11/16	1	2 1/8	1 7/8	6 1/4	4 23/32	3 1/8	30
2 3/4	E-P4B-TRB-2 3/4														29
2 15/16	E-P4B-TRB-2 15/16														28
3	E-P4B-TRB-3														29
70 mm	E-P4B-TRB-70MM														28
3 3/16	E-P4B-TRB-3 3/16	5	13 1/2	4 1/2	11 1/4	10 3/4	3/4	15/16	1 3/16	2 3/8	2 1/4	7 1/2	5 17/32	3 3/4	47
3 1/4	E-P4B-TRB-3 1/4														46
3 7/16	E-P4B-TRB-3 7/16														45
3 1/2	E-P4B-TRB-3 1/2														44
80 mm	E-P4B-TRB-80MM														47
85 mm	E-P4B-TRB-85MM	45													
90 mm	E-P4B-TRB-90MM	44													
3 15/16	E-P4B-TRB-3 15/16	6 1/4	15 1/4	4 1/2	12 3/4	12 1/4	3/4	7/8	1 1/8	2 1/4	2 7/16	8 1/2	6 1/16	4 1/4	72
4	E-P4B-TRB-4														71
100 mm	E-P4B-TRB-100MM														71
4 7/16	E-P4B-TRB-4 7/16														91
4 1/2	E-P4B-TRB-4 1/2														90
110 mm	E-P4B-TRB-110MM	92													
115 mm	E-P4B-TRB-115MM	89													
4 15/16	E-P4B-TRB-4 15/16	7 1/4	18 1/2	5 1/8	15 3/4	15 1/4	7/8	1	1 1/4	2 7/8	3	10 7/8	7 3/4	5 1/2	134
5	E-P4B-TRB-5														133
125 mm	E-P4B-TRB-125MM														134

FLANGE: FOUR-BOLT

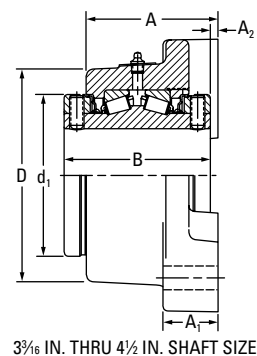
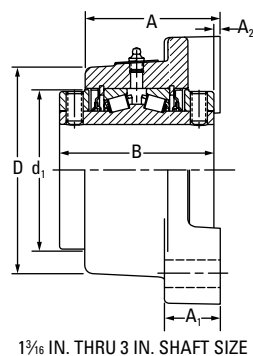
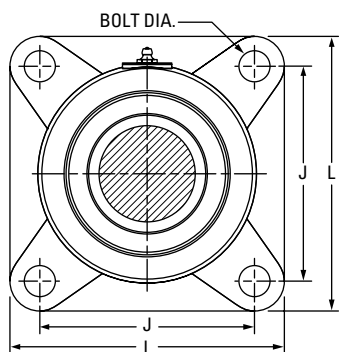

Shaft Dia.	Part No.	B	L	A	J	A <sub>2</sub>	Bolt Dia.	A <sub>1</sub>	D	d <sub>1</sub>	Approx. Wt.
in. mm		in.	in.	in.	in.	in.	in.	in.	in.	in.	lbs.
1 3/16	E-4BF-TRB-1 3/16	2 3/4	3 3/4	2 11/32	2 7/8	1/16	3/8	1	2 15/16	2 1/4	4
1 1/4	E-4BF-TRB-1 1/4										
1 3/8	E-4BF-TRB-1 3/8										
1 7/16	E-4BF-TRB-1 7/16	3	4 5/8	2 19/32	3 1/2	1/16	1/2	1 1/16	3 1/2	2 3/4	7
35 mm	E-4BF-TRB-35MM										
1 1/2	E-4BF-TRB-1 1/2										
1 5/8	E-4BF-TRB-1 5/8	3 3/8	5 3/8	2 31/32	4 1/8	1/8	1/2	1 3/16	4 3/16	3 3/16	11
1 11/16	E-4BF-TRB-1 11/16										
40 mm	E-4BF-TRB-40MM										
1 3/4	E-4BF-TRB-1 3/4	3 1/2	5 5/8	3 3/32	4 3/8	1/8	1/2	1 3/16	4 7/16	3 7/16	12
1 7/8	E-4BF-TRB-1 7/8										
1 15/16	E-4BF-TRB-1 15/16										
2	E-4BF-TRB-2	3 3/4	6 1/4	3 9/32	4 7/8	1/8	5/8	1 3/8	4 7/8	3 3/4	16
45 mm	E-4BF-TRB-45MM										
50 mm	E-4BF-TRB-50MM										
2 3/16	E-4BF-TRB-2 3/16	4	6 7/8	3 9/16	5 3/8	3/16	5/8	1 1/2	5 5/16	4 1/16	21
55 mm	E-4BF-TRB-55MM										
2 1/4	E-4BF-TRB-2 1/4										
2 7/16	E-4BF-TRB-2 7/16	4 1/2	7 3/4	3 15/16	6	3/16	3/4	1 5/8	6	4 23/32	21
2 1/2	E-4BF-TRB-2 1/2										
60 mm	E-4BF-TRB-60MM										
65 mm	E-4BF-TRB-65MM	5	9 1/4	4 1/2	7	1/4	3/4	1 7/8	7 1/4	5 17/32	21
2 11/16	E-4BF-TRB-2 11/16										
2 3/4	E-4BF-TRB-2 3/4										
2 15/16	E-4BF-TRB-2 15/16	5	9 1/4	4 1/2	7	1/4	3/4	1 7/8	7 1/4	5 17/32	29
3	E-4BF-TRB-3										
70 mm	E-4BF-TRB-70MM										
75 mm	E-4BF-TRB-75MM	6 1/4	10 1/4	5 5/8	7 3/4	1/4	7/8	2 1/8	8 1/4	6 1/16	28
3 3/16	E-4BF-TRB-3 3/16										
3 1/4	E-4BF-TRB-3 1/4										
3 7/16	E-4BF-TRB-3 7/16	6 3/4	10 7/8	5 15/16	8 3/4	3/8	7/8	2 7/16	8 3/4	6 47/64	29
3 1/2	E-4BF-TRB-3 1/2										
80 mm	E-4BF-TRB-80MM										
85 mm	E-4BF-TRB-85MM	6 3/4	10 7/8	5 15/16	8 3/4	3/8	7/8	2 7/16	8 3/4	6 47/64	52
90 mm	E-4BF-TRB-90MM										
3 15/16	E-4BF-TRB-3 15/16										
4	E-4BF-TRB-4	6 3/4	10 7/8	5 15/16	8 3/4	3/8	7/8	2 7/16	8 3/4	6 47/64	75
100 mm	E-4BF-TRB-100MM										
4 7/16	E-4BF-TRB-4 7/16										
4 1/2	E-4BF-TRB-4 1/2	6 3/4	10 7/8	5 15/16	8 3/4	3/8	7/8	2 7/16	8 3/4	6 47/64	76
110 mm	E-4BF-TRB-110MM										
115 mm	E-4BF-TRB-115MM										

# TAPERED ROLLER BEARING TYPE E HOUSED UNITS

FLANGE: PILOTED

## FLANGE: PILOTED

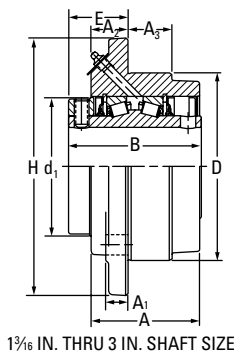
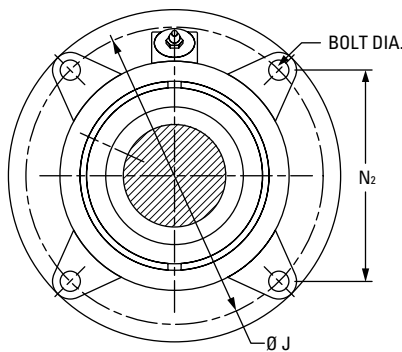

1 1/16 IN. THRU 3 IN. SHAFT SIZE

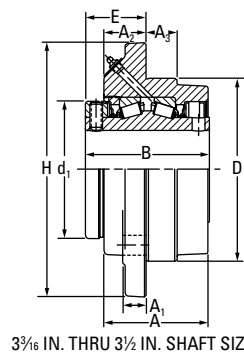

3 3/16 IN. THRU 3 1/2 IN. SHAFT SIZE

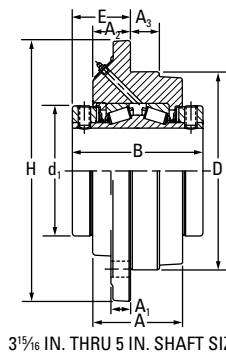

3 15/16 IN. THRU 5 IN. SHAFT SIZE

Shaft Dia.	Part No.	B	H	A	N <sub>2</sub>	J	A <sub>3</sub>	Bolt Dia.	E	A <sub>1</sub>	D <sup>(1)</sup>	d <sub>1</sub>	A <sub>2</sub>	Approx. Wt.
in. mm		in.	in.	in.	in.	in.	in.	in.	in.	in.	in.	in.	in.	lbs.
1 3/16	E-PF-TRB-1 3/16	2 3/4	5	2 7/32	2.92	4 1/8	3/4	3/8	1 5/16	7/16	3 3/8	2 1/4	27/32	5
1 1/4	E-PF-TRB-1 1/4													
1 3/8	E-PF-TRB-1 3/8													
1 7/16	E-PF-TRB-1 7/16	3	5 1/4	2 15/32	3.09	4 3/8	7/8	3/8	1 1/2	1/2	3 5/8	2 3/4	1 1/32	6
35 mm	E-PF-TRB-35MM													
1 1/2	E-PF-TRB-1 1/2	3 3/8	6 1/8	2 25/32	3.62	5 1/8	1 1/16	7/16	1 9/16	1/2	4 1/4	3 3/16	1 1/32	9
1 5/8	E-PF-TRB-1 5/8													
1 11/16	E-PF-TRB-1 11/16													
40 mm	E-PF-TRB-40MM													
1 3/4	E-PF-TRB-1 3/4	3 1/2	6 3/8	2 29/32	3.80	5 3/8	1 3/16	7/16	1 9/16	9/16	4 1/2	3 7/16	1 1/32	10
1 7/8	E-PF-TRB-1 7/8													
1 15/16	E-PF-TRB-1 15/16													
2	E-PF-TRB-2													
45 mm	E-PF-TRB-45MM													
50 mm	E-PF-TRB-50MM	3 3/4	7 1/8	3 3/32	4.24	6	1 3/16	1/2	1 11/16	9/16	5	3 3/4	1 3/32	13
2 3/16	E-PF-TRB-2 3/16													
55 mm	E-PF-TRB-55MM													
2 1/4	E-PF-TRB-2 1/4	4	7 5/8	3 5/16	4.60	6 1/2	1 5/16	1/2	1 13/16	5/8	5 1/2	4 1/16	1 3/16	17
2 7/16	E-PF-TRB-2 7/16													
2 1/2	E-PF-TRB-2 1/2													
60 mm	E-PF-TRB-60MM													
65 mm	E-PF-TRB-65MM													
2 11/16	E-PF-TRB-2 11/16													
2 3/4	E-PF-TRB-2 3/4													
2 15/16	E-PF-TRB-2 15/16													
3	E-PF-TRB-3	4 1/2	8 3/4	3 11/16	5.30	7 1/2	1 1/2	5/8	2	3/4	6 3/8	4 23/32	1 1/4	25
70 mm	E-PF-TRB-70MM													
75 mm	E-PF-TRB-75MM													
3 3/16	E-PF-TRB-3 3/16													
3 1/4	E-PF-TRB-3 1/4													
3 7/16	E-PF-TRB-3 7/16													
3 1/2	E-PF-TRB-3 1/2	5	10 1/4	4 3/16	6.10	8 5/8	1 1/4	3/4	2 7/16	15/16	7 3/8	5 17/32	1 11/16	41
80 mm	E-PF-TRB-80MM													
85 mm	E-PF-TRB-85MM													
90 mm	E-PF-TRB-90MM													
3 15/16	E-PF-TRB-3 15/16													
4	E-PF-TRB-4	6 1/4	10 7/8	4 1/2	6.63	9 3/8	1 1/2	3/4	2 11/16	1	8 1/8	6 1/16	1 13/16	58
100 mm	E-PF-TRB-100MM													
4 7/16	E-PF-TRB-4 7/16													
4 1/2	E-PF-TRB-4 1/2	6 3/4	13 1/2	4 5/8	5 7/8 <sup>(2)</sup>	11 3/4	1 1/2	3/4 <sup>(2)</sup>	3	1	10 1/4	6 47/64	1 15/16	92
110 mm	E-PF-TRB-110MM													
115 mm	E-PF-TRB-115MM													
4 15/16	E-PF-TRB-4 15/16													
5	E-PF-TRB-5	7 1/4	14 3/4	5 1/16	6 3/8 <sup>(2)</sup>	12 3/4	1 3/4	7/8 <sup>(2)</sup>	2 31/32	1 1/4	11	7 3/4	1 7/8	125
125 mm	E-PF-TRB-125MM													

<sup>(1)</sup>+0.000 in./ 0.002 in.

<sup>(2)</sup>Six holes equally spaced (chordal spacing shown).

Note: 1 3/16 to 3 1/2 utilize one collar; 3 15/16 to 5 utilize two collars.

TAKE-UP: WIDE SLOT

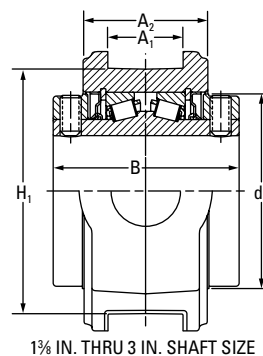
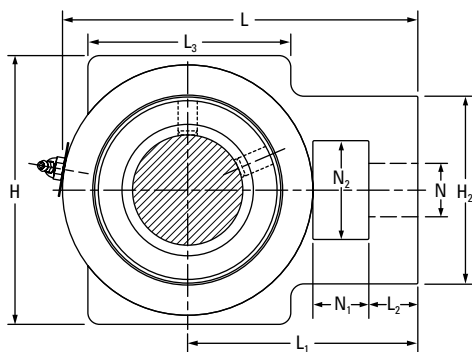

1 3/8 IN. THRU 3 IN. SHAFT SIZE

Shaft Dia.	Part No.	B	L	A <sub>1</sub>	L <sub>3</sub>	L <sub>1</sub>	N	L <sub>2</sub>	N <sub>1</sub>	H <sub>2</sub>	N <sub>2</sub>	d <sub>1</sub>	H <sub>1</sub>	H	A <sub>2</sub>	Approx. Wt.
in. mm		in.	in.	in.	in.	in.	in.	in.	in.	in.	in.	in.	in.	in.	in.	lbs.
1 3/8	E-TU-TRB-1 3/8	3	5 3/32	17/32	2 3/4	3 7/32	7/8	11/16	5/8	2 7/16	1 7/16	2 3/4	3 1/2	4 1/8	2 1/16	7
1 7/16	E-TU-TRB-1 7/16															
35 mm	E-TU-TRB-35MM															
1 1/2	E-TU-TRB-1 1/2	3 3/8	6	11/16	3 1/4	3 13/16	1 1/8	15/16	3/4	3 5/16	1 15/16	3 3/16	4	4 3/4	2 5/16	12
1 5/8	E-TU-TRB-1 5/8															
1 11/16	E-TU-TRB-1 11/16															
40 mm	E-TU-TRB-40MM															
1 3/4	E-TU-TRB-1 3/4															
1 7/8	E-TU-TRB-1 7/8	3 1/2	6 5/16	11/16	3 3/4	3 5/16	1 1/8	15/16	3/4	3 5/16	1 15/16	3 7/16	4	4 3/4	2 7/16	11
1 15/16	E-TU-TRB-1 15/16															
2	E-TU-TRB-2															
45 mm	E-TU-TRB-45MM															
50 mm	E-TU-TRB-50MM	3 3/4	7 1/8	13/16	3 3/4	4 5/8	1 1/4	1	1 1/4	3 7/8	2 1/4	3 3/4	4 1/2	5 1/4	2 9/16	13
2 3/16	E-TU-TRB-2 3/16															
55 mm	E-TU-TRB-55MM															
2 1/4	E-TU-TRB-2 1/4	4	7 13/16	1 1/16	4 1/2	5 1/16	1 3/8	1 1/16	1 1/4	4 5/16	2 1/2	4 1/16	5 1/8	6	2 3/4	21
2 7/16	E-TU-TRB-2 7/16															
2 1/2	E-TU-TRB-2 1/2															
60 mm	E-TU-TRB-60MM															
65 mm	E-TU-TRB-65MM															
2 11/16	E-TU-TRB-2 11/16	4 1/2	9 3/16	1 13/16	4 3/4	5 7/8	1 11/16	1 1/8	1 1/2	4 15/16	2 3/4	4 23/32	5 5/16	6 3/4	3	20
2 3/4	E-TU-TRB-2 3/4															
2 15/16	E-TU-TRB-2 15/16															
3	E-TU-TRB-3															
70 mm	E-TU-TRB-70MM															
75 mm	E-TU-TRB-75MM															29

# TAPERED ROLLER BEARING TYPE E HOUSED UNITS

TAKE-UP: TOP ANGLE

## TAKE-UP: TOP ANGLE

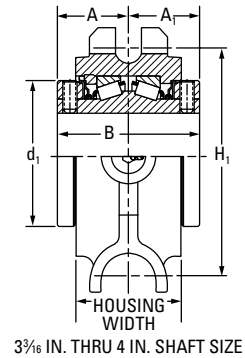
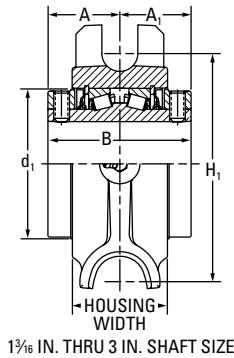
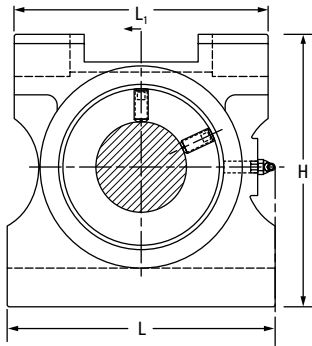

Shaft Dia.	Part No.	B	H <sub>1</sub>	H	d <sub>1</sub>	A	A <sub>1</sub>	Housing Width	L	L <sub>1</sub>	Approx. Wt.
in. mm		in.	in.	in.	in.	in.	in.	in.	in.	in.	lbs.
1 3/4	E-TTU-TRB-1 3/4	3 1/2	5 3/16	6 3/8	3 7/16	1 3/4	1 3/4	2 9/16	6 1/2	6	14
1 7/8	E-TTU-TRB-1 7/8										
1 15/16	E-TTU-TRB-1 15/16										
2	E-TTU-TRB-2										
45 mm	E-TTU-TRB-45MM										
50 mm	E-TTU-TRB-50MM	3 3/4	5 13/16	6 7/8	3 3/4	1 7/8	1 7/8	2 9/16	6 3/4	7	17
2 3/16	E-TTU-TRB-2 3/16										
55 mm	E-TTU-TRB-55MM										
2 1/4	E-TTU-TRB-2 1/4										
2 7/16	E-TTU-TRB-2 7/16										
2 1/2	E-TTU-TRB-2 1/2	4	6 1/4	7 7/16	4 1/16	2	2	3	7 1/2	7	21
60 mm	E-TTU-TRB-60MM										
65 mm	E-TTU-TRB-65MM										
2 11/16	E-TTU-TRB-2 11/16										
2 3/4	E-TTU-TRB-2 3/4										
2 15/16	E-TTU-TRB-2 15/16	4 1/2	7 3/16	8 5/16	4 23/32	2 1/4	2 1/4	3	8 1/2	8	28
3	E-TTU-TRB-3										
70 mm	E-TTU-TRB-70MM										
75 mm	E-TTU-TRB-75MM										
3 3/16	E-TTU-TRB-3 3/16										
3 1/4	E-TTU-TRB-3 1/4	5	8 5/16	9 5/8	5 17/32	2 1/2	2 1/2	3 3/4	9 1/2	9	44
3 7/16	E-TTU-TRB-3 7/16										
3 1/2	E-TTU-TRB-3 1/2										
80 mm	E-TTU-TRB-80MM										
85 mm	E-TTU-TRB-85MM										
90 mm	E-TTU-TRB-90MM	6 1/4	9 1/16	11	6 1/16	3 1/8	3 1/8	4 3/4	11	10 1/2	70
3 15/16	E-TTU-TRB-3 15/16										
4	E-TTU-TRB-4										
100 mm	E-TTU-TRB-100MM										

# ***INDEX***

## **TAPERED ROLLER BEARING TYPE E HOUSED UNITS**

E-4BF Flange: Four-Bolt .....	B-19
E-P2B Pillow Block: Two-Bolt Base .....	B-17
E-P4B Pillow Block: Four-Bolt Base .....	B-18
E-PF Flange: Piloted .....	B-20
E-TTU Take-Up: Top Angle .....	B-22
E-TU Take-Up: Wide Slot .....	B-21
Introduction and Engineering .....	B-2
Tapered Roller Bearing Type E Housed Units .....	B-1

# TIMKEN

The Timken team applies their know-how to improve the reliability and performance of machinery in diverse markets worldwide. The company designs, makes and markets high-performance steel as well as mechanical components, including bearings, gears, chain and related mechanical power transmission products and services.

[www.timken.com](http://www.timken.com)



Stronger. Commitment. Stronger. Value. Stronger. Worldwide. Stronger. Together. | Stronger. By Design.

Price: USD \$75